

www.net-conveyor.com

主动链轮和从动轮

SPROCKETS & IDLER WHEELS

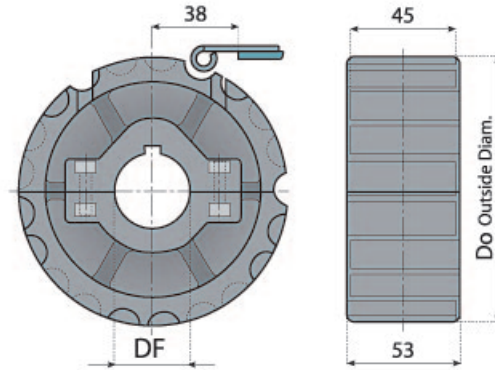



分体式主动轮 (注塑)
SPLIT SPROCKETS (INJECTION)

适用于 812-815-881M 链条
FOR 812-815-881M

编号 CODE	齿数 Z	外径 Do mm	孔径 DF mm
A01021	21	129	25/30/35/40
A01023	23	142	25/30/35/40
A01025	25	154	25/30/35/40

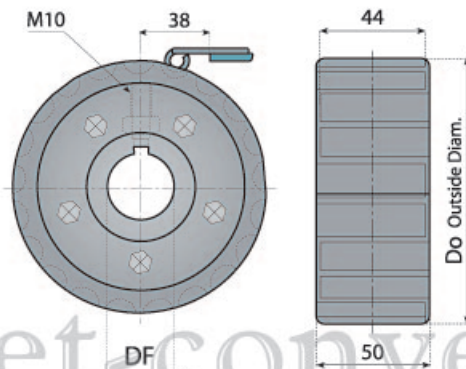

整体式主动轮 (注塑)
SINGLE-PIECE SPROCKETS (INJECTION)

适用于 812-815-881M 链条
FOR 812-815-881M

编号 CODE	齿数 Z	外径 Do mm	孔径 DF mm
A02021	21	129	25/30/35/40
A02023	23	142	25/30/35/40
A02025	25	154	25/30/35/40

适用于 812-815-881M 链条
FOR 812-815-881M

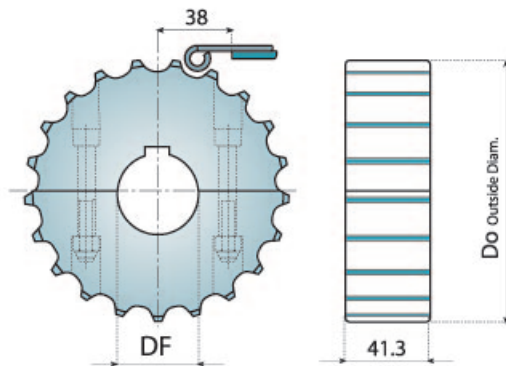

分体式主动轮 (机加工)
SPLIT SPROCKETS (MACHINED)

编号 CODE	齿数 Z	外径 Do mm	孔径 DF mm
A03017-1	17	104	25/30/35/40
A03019-1	19	117	25/30/35/40
A03021-1	21	129	25/30/35/40
A03023-1	23	142	25/30/35/40
A03025-1	25	154	25/30/35/40
A03027-1	27	166.8	25/30/35/40
A03029-1	29	178.5	25/30/35/40

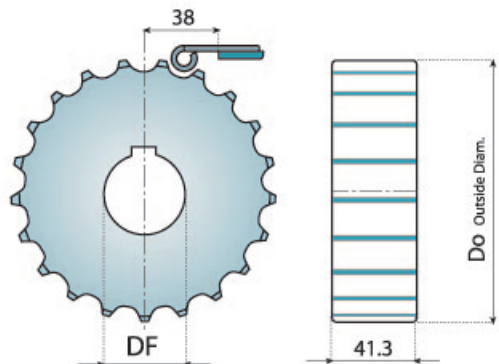

整体式主动轮 (机加工)
SINGLE-PIECE SPROCKETS (MACHINED)

编号 CODE	齿数 Z	外径 Do mm	孔径 DF mm
A03017-2	17	104	25/30/35/40
A03019-2	19	117	25/30/35/40
A03021-2	21	129	25/30/35/40
A03023-2	23	142	25/30/35/40
A03025-2	25	154	25/30/35/40
A03027-2	27	166.8	25/30/35/40
A03029-2	29	178.5	25/30/35/40

从动轮 Idler Wheels

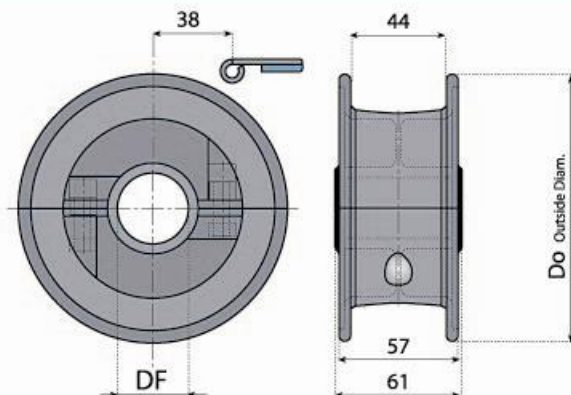

适用于 812-815-881M-820 链条
FOR 812-815-881M-820

编号 CODE	齿数 Z	外径 Do mm	孔径 DF mm
A04019-ID	19	117	25/30/35/40
A04021-ID	21	129	25/30/35/40
A04023-ID	23	142	25/30/35/40
A04025-ID	25	154	25/30/35/40

分体式从动轮 (注塑)
SPLIT IDLER WHEELS (INJECTION)

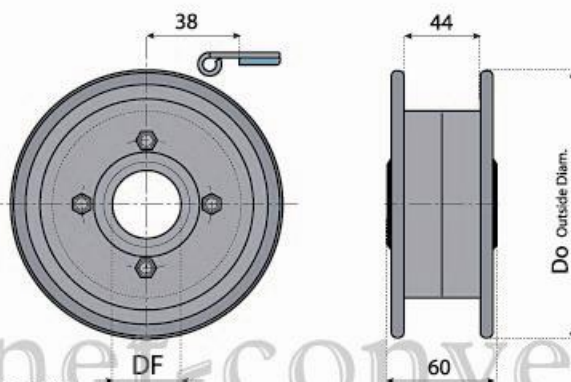

适用于 812-815-881M-820 链条
FOR 812-815-881M-820

编号 CODE	齿数 Z	外径 Do mm	孔径 DF mm
A05019-ID	19	117	25/30/35/40
A05021-ID	21	129	25/30/35/40
A05023-ID	23	142	25/30/35/40
A05025-ID	25	154	25/30/35/40

整体式从动轮 (注塑)
SINGLE-PIECE IDLER WHEELS (INJECTION)

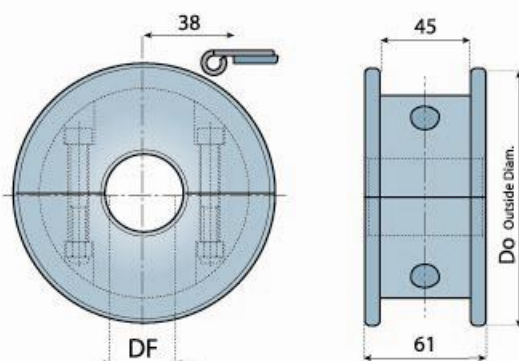

适用于 812-815-881M-820 链条
FOR 812-815-881M-820

编号 CODE	齿数 Z	外径 Do mm	孔径 DF mm
A06017-ID-1	17	104	25/30/35/40
A06019-ID-1	19	117	25/30/35/40
A06021-ID-1	21	129	25/30/35/40
A06023-ID-1	23	142	25/30/35/40
A06025-ID-1	25	154	25/30/35/40
A06027-ID-1	27	166.8	25/30/35/40
A06029-ID-1	29	178.5	25/30/35/40

分体式从动轮 (机加工)
SPLIT IDLER WHEELS (MACHINED)

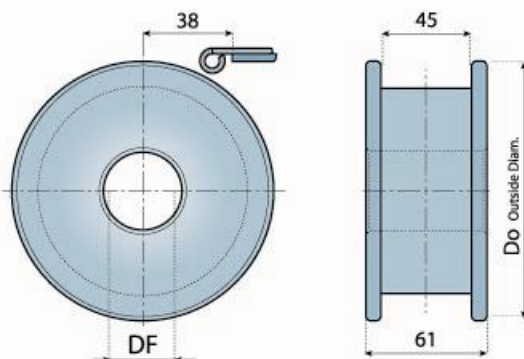

编号 CODE	齿数 Z	外径 Do mm	孔径 DF mm
A06017-ID-2	17	104	25/30/35/40
A06019-ID-2	19	117	25/30/35/40
A06021-ID-2	21	129	25/30/35/40
A06023-ID-2	23	142	25/30/35/40
A06025-ID-2	25	154	25/30/35/40
A06027-ID-2	27	166.8	25/30/35/40
A06029-ID-2	29	178.5	25/30/35/40

整体式从动轮 (机加工)
SINGLE-PIECE IDLER WHEELS (MACHINED)



主动轮 (机加工)
SPROCKETS (MACHINED)

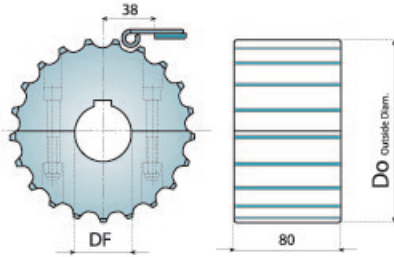

分体式
SPLIT

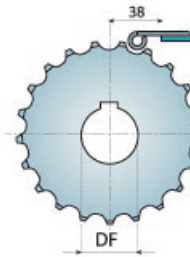

整体式
SINGLE - PIECE

适用于 802-805 链条
FOR 802-805

编号 CODE	齿数 Z	外径 Do mm	孔径 DF mm
B08019	19	117	25/30/35/40
B08021	21	129	25/30/35/40
B08023	23	142	25/30/35/40
B08025	25	154	25/30/35/40
B08027	27	166.8	25/30/35/40
B08029	29	178.5	25/30/35/40



从动轮 (注塑)
IDLER WHEELS (INJECTION)

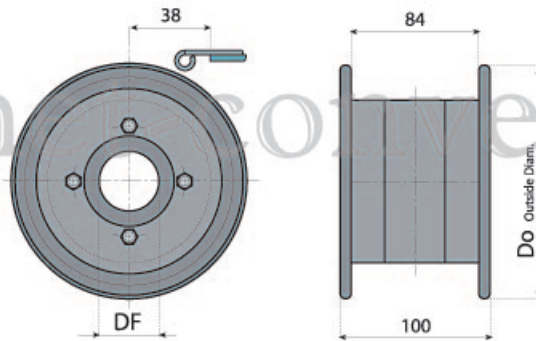

适用于 802-805 链条
FOR 802-805

编号 CODE	齿数 Z	外径 Do mm	孔径 DF mm
B09019-ID	19	117	25/30/35/40
B09021-ID	21	129	25/30/35/40
B09023-ID	23	142	25/30/35/40
B09025-ID	25	154	25/30/35/40



从动轮 (机加工)
IDLER WHEELS (MACHINED)

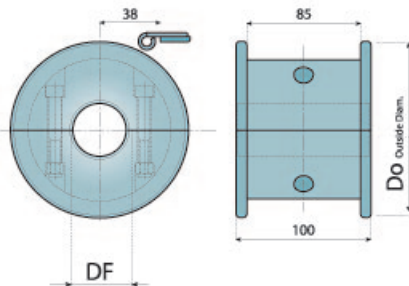

分体式
SPLIT

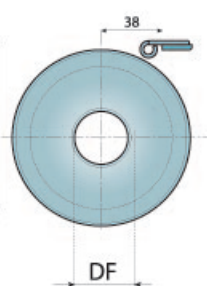

整体式
SINGLE - PIECE

适用于 802-805 链条
FOR 802-805

编号 CODE	齿数 Z	外径 Do mm	孔径 DF mm
B10019-ID	19	117	25/30/35/40
B10021-ID	21	129	25/30/35/40
B10023-ID	23	142	25/30/35/40
B10025-ID	25	154	25/30/35/40
B10027-ID	27	166.8	25/30/35/40
B10029-ID	29	178.5	25/30/35/40

主动链轮和从动轮

Sprockets & Idler Wheels



适用于 8157-8857M 链条
FOR 8157-8857M

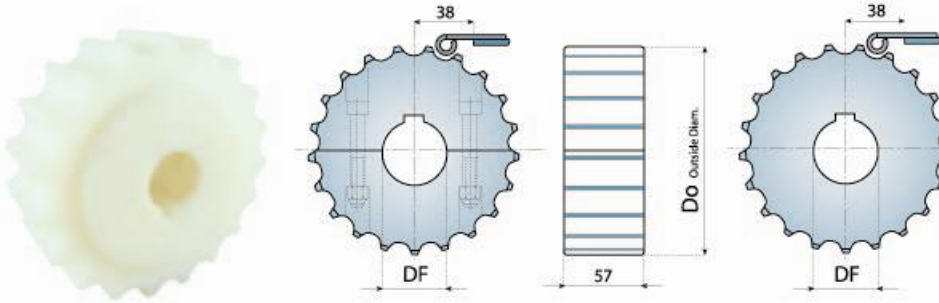

主动轮 (机加工)
SPROCKETS (MACHINED)

分体式
SPLIT

整体式
SINGLE - PIECE

编号 CODE	齿数 Z	外径 Do mm	孔径 DF mm
C12017	17	104	25/30/35/40
C12019	19	117	25/30/35/40
C12021	21	129	25/30/35/40
C12023	23	142	25/30/35/40
C12025	25	154	25/30/35/40
C12027	27	166.8	25/30/35/40
C12029	29	178.5	25/30/35/40

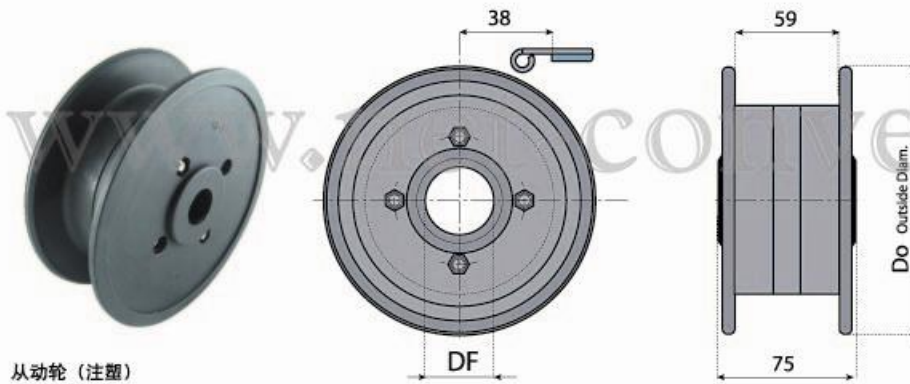

从动轮 (注塑)
IDLER WHEELS (INJECTION)

适用于 8157-8857M 链条
FOR 8157-8857M

编号 CODE	齿数 Z	外径 Do mm	孔径 DF mm
C13019-ID	19	117	25/30/35/40
C13021-ID	21	129	25/30/35/40
C13023-ID	23	142	25/30/35/40
C13025-ID	25	154	25/30/35/40

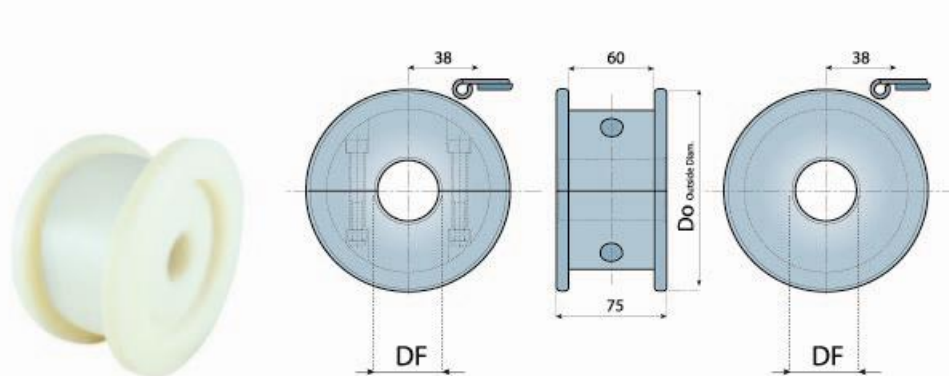

从动轮 (机加工)
IDLER WHEELS (MACHINED)

分体式
SPLIT

整体式
SINGLE - PIECE

适用于 8157-8857M 链条
FOR 8157-8857M

编号 CODE	齿数 Z	外径 Do mm	孔径 DF mm
C14017-ID	17	104	25/30/35/40
C14019-ID	19	117	25/30/35/40
C14021-ID	21	129	25/30/35/40
C14023-ID	23	142	25/30/35/40
C14025-ID	25	154	25/30/35/40
C14027-ID	27	166.8	25/30/35/40
C14029ID	29	178.5	25/30/35/40



主动轮 (机加工)
SPROCKETS (MACHINED)

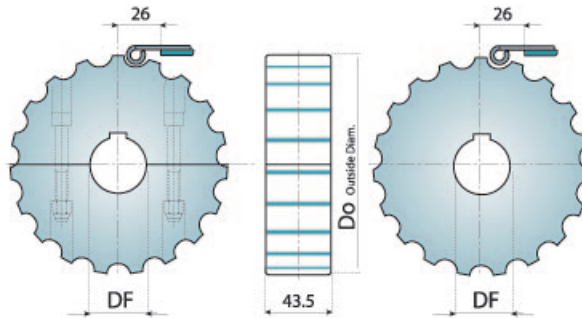

分体式
SPLIT

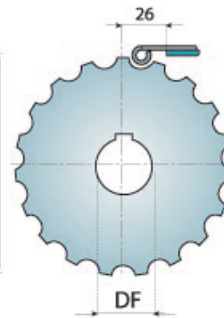

整体式
SINGLE - PIECE

适用于 512-515 链条
FOR 512-515

编号 CODE	齿数 Z	外径 Do mm	孔径 DF mm
D15013	13	108	25/30/35/40
D15015	15	124	25/30/35/40
D15017	17	138	25/30/35/40
D15019	19	156	25/30/35/40
D15021	21	173	25/30/35/40
D15023	23	190	25/30/35/40
D15025	25	206	25/30/35/40



从动轮 (机加工)
IDLER WHEELS (MACHINED)

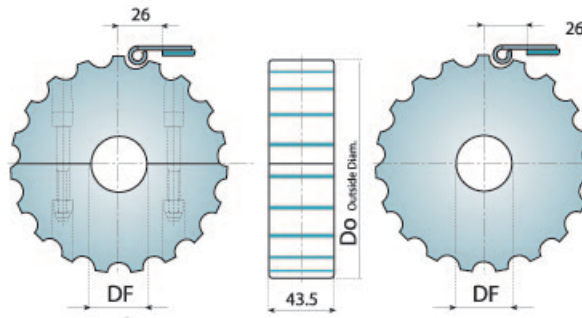

分体式
SPLIT

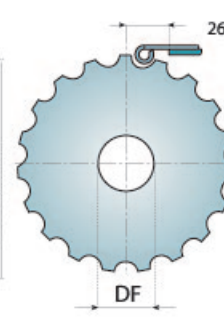

整体式
SINGLE - PIECE

适用于 512-515 链条
FOR 512-515

编号 CODE	齿数 Z	外径 Do mm	孔径 DF mm
D16013-ID	13	108	25/30/35/40
D16015-ID	15	124	25/30/35/40
D16017-ID	17	138	25/30/35/40
D16019-ID	19	156	25/30/35/40
D16021-ID	21	173	25/30/35/40
D16023-ID	23	190	25/30/35/40
D16025-ID	25	206	25/30/35/40



主动轮 (机加工)
SPROCKETS (MACHINED)

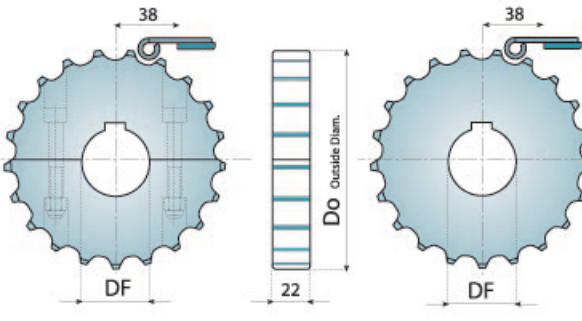

分体式
SPLIT

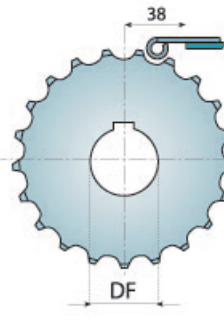

整体式
SINGLE - PIECE

适用于 812-815MINI 链条
FOR 812-815MINI

编号 CODE	齿数 Z	外径 Do mm	孔径 DF mm
E17019	19	117	25/30/35/40
E17021	21	129	25/30/35/40
E17023	23	142	25/30/35/40
E17025	25	154	25/30/35/40



从动轮 (机加工)
IDLER WHEELS (MACHINED)

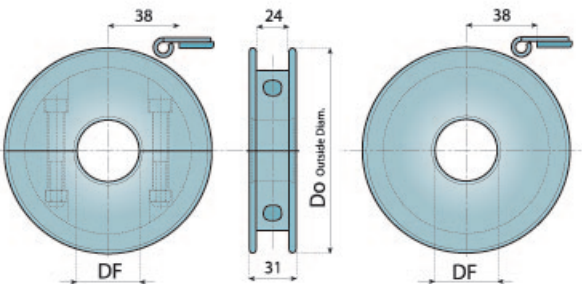

分体式
SPLIT

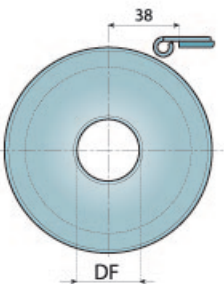

整体式
SINGLE - PIECE

适用于 812-815MINI 链条
FOR 812-815MINI

编号 CODE	齿数 Z	外径 Do mm	孔径 DF mm
E18019-ID	19	117	25/30/35/40
E18021-ID	21	129	25/30/35/40
E18023-ID	23	142	25/30/35/40
E18025-ID	25	154	25/30/35/40

主动链轮和从动轮

Sprockets & Idler Wheels



主动轮 (注塑)
SPLIT SPROCKETS (INJECTION)

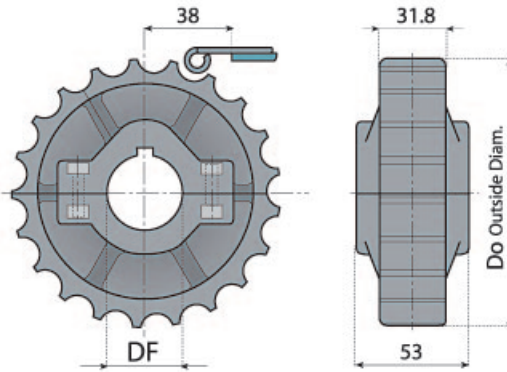

适用于 881BEVEL-881TAB 链条
FOR 881BEVEL-881TAB

编号 CODE	齿数 Z	外径 Do mm	孔径 DF mm
F19021	21	129	25/30/35/40
F19023	23	142	25/30/35/40
F19025	25	154	25/30/35/40



主动轮 (机加工)
IDLER WHEELS (MACHINED)

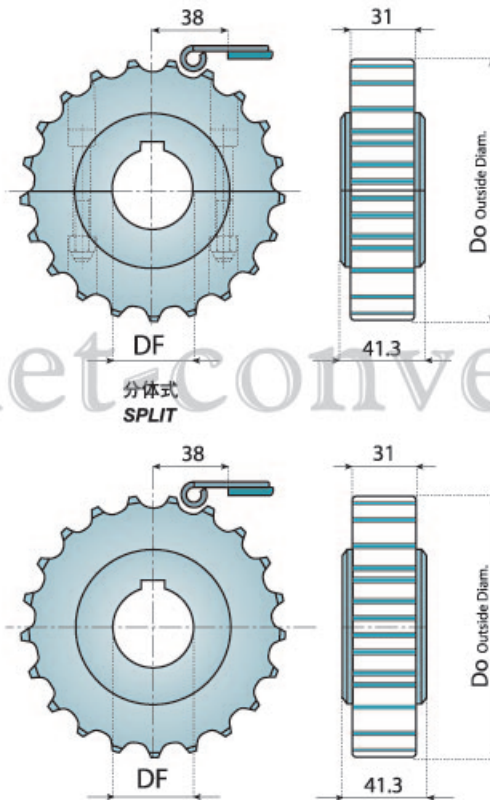

适用于 881BEVEL-881TAB 链条
FOR 881BEVEL-881TAB

编号 CODE	齿数 Z	外径 Do mm	孔径 DF mm
F20017-1	17	104	25/30/35/40
F20019-1	19	117	25/30/35/40
F20021-1	21	129	25/30/35/40
F20023-1	23	142	25/30/35/40
F20025-1	25	154	25/30/35/40
F20027-1	27	166.8	25/30/35/40
F20029-1	29	178.5	25/30/35/40

编号 CODE	齿数 Z	外径 Do mm	孔径 DF mm
F20017-2	17	104	25/30/35/40
F20019-2	19	117	25/30/35/40
F20021-2	21	129	25/30/35/40
F20023-2	23	142	25/30/35/40
F20025-2	25	154	25/30/35/40
F20027-2	27	166.8	25/30/35/40
F20029-2	29	178.5	25/30/35/40

整体式
SINGLE - PIECE



从动轮 (机加工)
IDLER WHEELS (MACHINED)

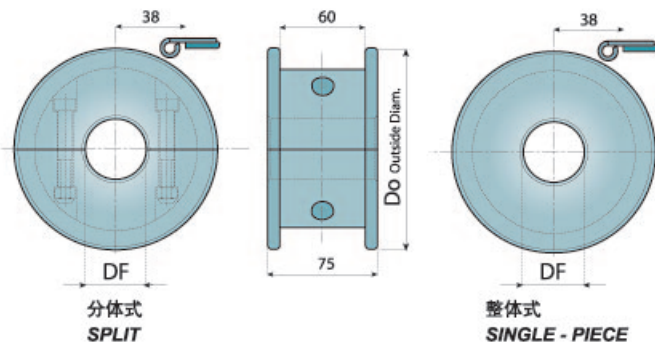

适用于 881TAB 链条
FOR 881TAB

编号 CODE	齿数 Z	外径 Do mm	孔径 DF mm
F21017-ID	17	104	25/30/35/40
F21019-ID	19	117	25/30/35/40
F21021-ID	21	129	25/30/35/40
F21023-ID	23	142	25/30/35/40
F21025-ID	25	154	25/30/35/40
F21027-ID	27	166.8	25/30/35/40
F21029-ID	29	178.5	25/30/35/40



分体式主动轮 (注塑)
SPLIT SPROCKETS (INJECTION)

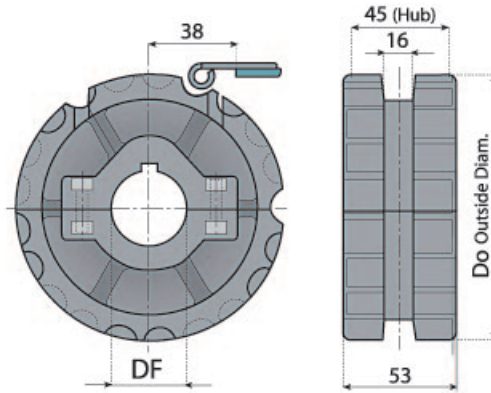

适用于 820-LBP831 链条
FOR 820-LBP831

编号 CODE	齿数 Z	外径 Do mm	孔径 DF mm
G22021	21	129	25/30/35/40
G22023	23	142	25/30/35/40
G22025	25	154	25/30/35/40



整体式主动轮 (注塑)
SINGLE - PIECE SPROCKETS (INJECTION)

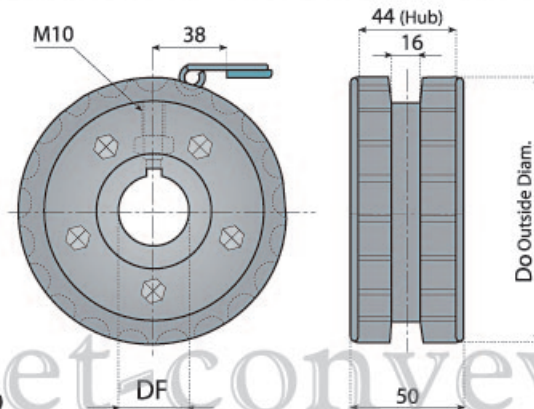

适用于 820-LBP831 链条
FOR 820-LBP831

编号 CODE	齿数 Z	外径 Do mm	孔径 DF mm
G23021	21	129	25/30/35/40
G23023	23	142	25/30/35/40
G23025	25	154	25/30/35/40

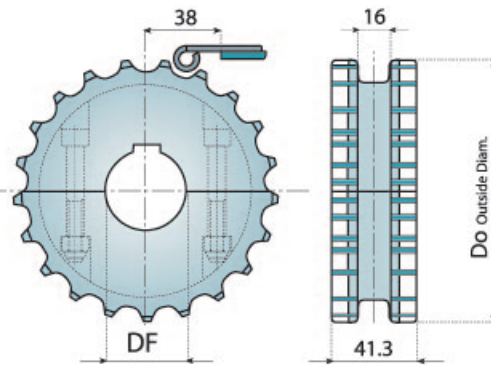

分体式主动轮 (机加工)
SPLIT SPROCKETS (MACHINED)

适用于 820-LBP831 链条
FOR 820-LBP831

编号 CODE	齿数 Z	外径 Do mm	孔径 DF mm
G24017-1	17	104	25/30/35/40
G24019-1	19	117	25/30/35/40
G24021-1	21	129	25/30/35/40
G24023-1	23	142	25/30/35/40
G24025-1	25	154	25/30/35/40
G24027-1	27	166.8	25/30/35/40
G24029-1	29	178.5	25/30/35/40

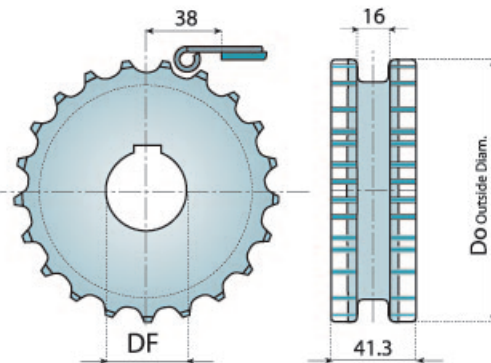

整体式主动轮 (机加工)
SINGLE - PIECE SPROCKETS (MACHINED)

编号 CODE	齿数 Z	外径 Do mm	孔径 DF mm
G24017-2	17	104	25/30/35/40
G24019-2	19	117	25/30/35/40
G24021-2	21	129	25/30/35/40
G24023-2	23	142	25/30/35/40
G24025-2	25	154	25/30/35/40
G24027-2	27	166.8	25/30/35/40
G24029-2	29	178.5	25/30/35/40

从动轮

Idler Wheels

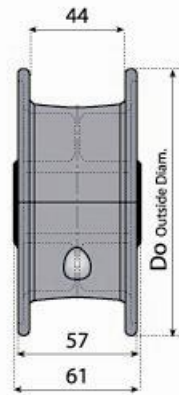
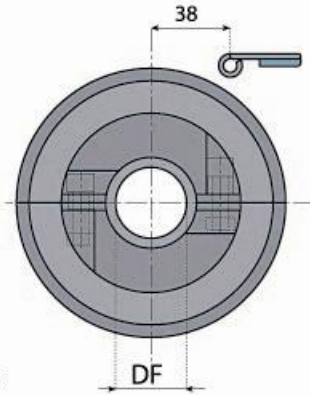

分体式从动轮 (注塑)
SPLIT IDLER WHEELS (INJECTION)

适用于 820-LBP831 链条
FOR 820-LBP831

编号 CODE	齿数 Z	外径 Do mm	孔径 DF mm
G25019-ID	19	117	25/30/35/40
G25021-ID	21	129	25/30/35/40
G25023-ID	23	142	25/30/35/40
G25025-ID	25	154	25/30/35/40

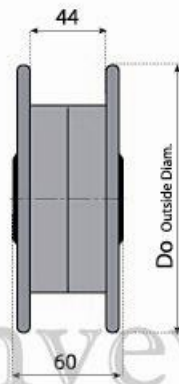
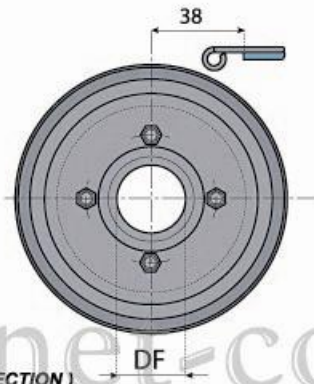

整体式从动轮 (注塑)
SINGLE - PIECE IDLER WHEELS (INJECTION)

适用于 820-LBP831 链条
FOR 820-LBP831

编号 CODE	齿数 Z	外径 Do mm	孔径 DF mm
G26019-ID	19	117	25/30/35/40
G26021-ID	21	129	25/30/35/40
G26023-ID	23	142	25/30/35/40
G26025-ID	25	154	25/30/35/40

SPROCKETS & IDLER WHEELS

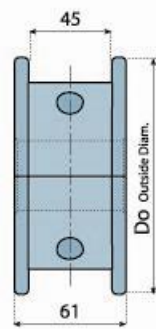
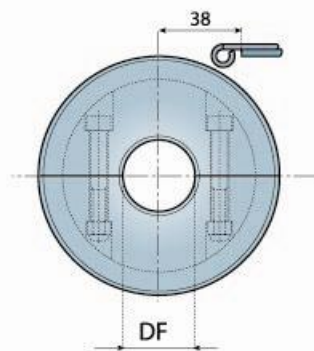

分体式从动轮 (机加工)
SPLIT IDLER WHEELS (MACHINED)

适用于 820-LBP831 链条
FOR 820-LBP831

编号 CODE	齿数 Z	外径 Do mm	孔径 DF mm
G27017-ID-1	17	104	25/30/35/40
G27019-ID-1	19	117	25/30/35/40
G27021-ID-1	21	129	25/30/35/40
G27023-ID-1	23	142	25/30/35/40
G27025-ID-1	25	154	25/30/35/40
G27027-ID-1	27	166.8	25/30/35/40
G27029-ID-1	29	178.5	25/30/35/40

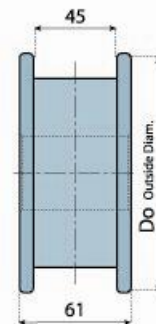
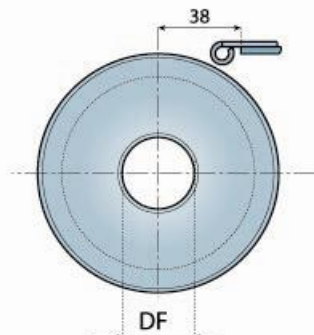

整体式从动轮 (机加工)
SINGLE - PIECE IDLER WHEELS (MACHINED)

编号 CODE	齿数 Z	外径 Do mm	孔径 DF mm
G27017-ID-2	17	104	25/30/35/40
G27019-ID-2	19	117	25/30/35/40
G27021-ID-2	21	129	25/30/35/40
G27023-ID-2	23	142	25/30/35/40
G27025-ID-2	25	154	25/30/35/40
G27027-ID-2	27	166.8	25/30/35/40
G27029-ID-2	29	178.5	25/30/35/40

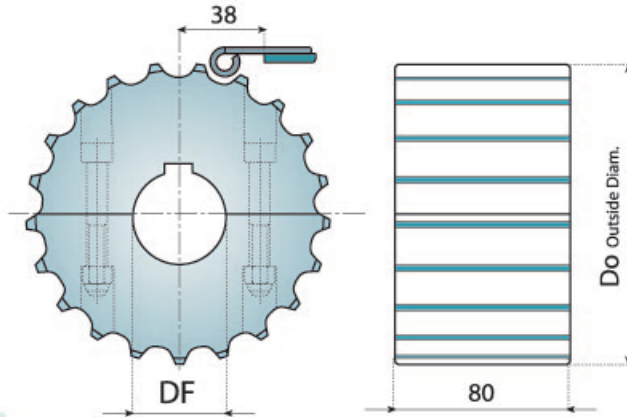

分体式主动轮 (机加工)
SPLIT SPROCKETS (MACHINED)

适用于 821-LBP821 链条
FOR 821-LBP821

编号 CODE	齿数 Z	外径 Do mm	孔径 DF mm
H29019-1	19	117	25/30/35/40
H29021-1	21	129	25/30/35/40
H29023-1	23	142	25/30/35/40
H29025-1	25	154	25/30/35/40
H29027-1	27	166.8	25/30/35/40
H29029-1	29	178.5	25/30/35/40

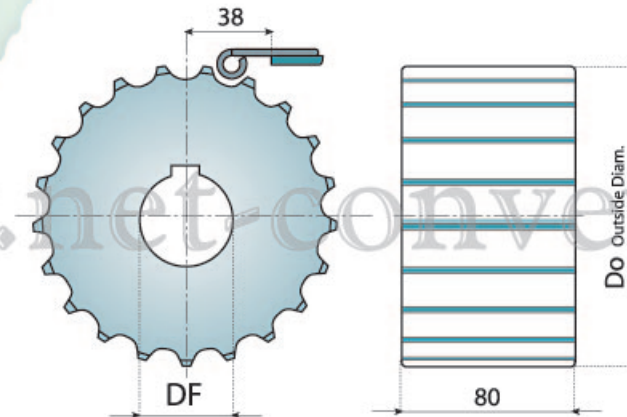

整体式主动轮 (机加工)
SINGLE - PIECE SPROCKETS (MACHINED)

编号 CODE	齿数 Z	外径 Do mm	孔径 DF mm
H29019-2	19	117	25/30/35/40
H29021-2	21	129	25/30/35/40
H29023-2	23	142	25/30/35/40
H29025-2	25	154	25/30/35/40
H29027-2	27	166.8	25/30/35/40
H29029-2	29	178.5	25/30/35/40

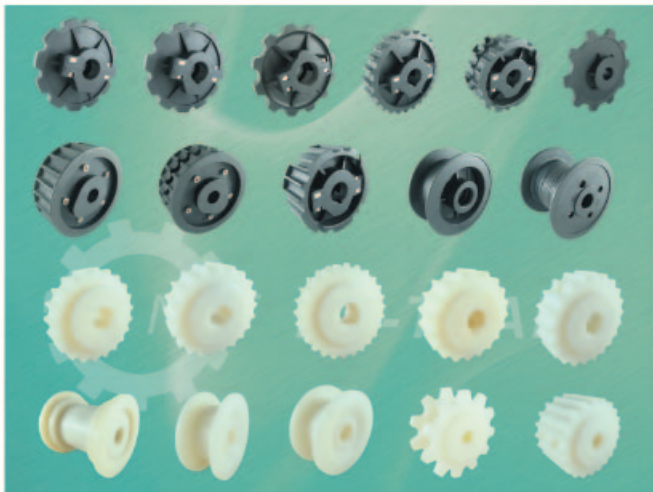

从动轮

Idler Wheels

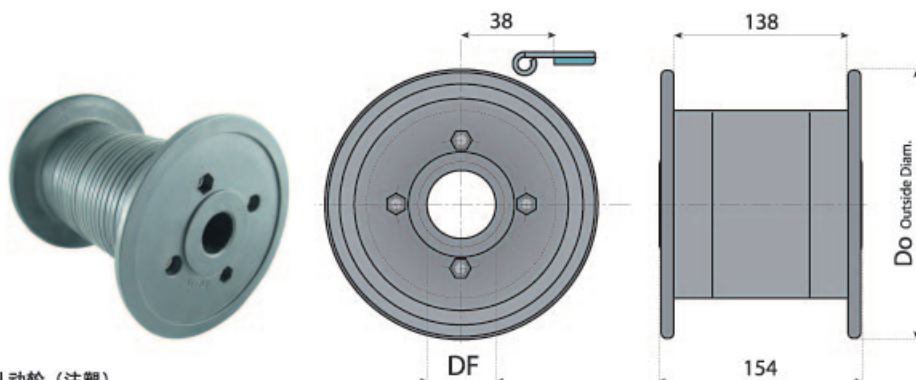

从动轮 (注塑)
IDLER WHEELS (INJECTION)

适用于 821-LBP821 链条
FOR 821-LBP821

编号 CODE	齿数 Z	外径 Do mm	孔径 DF mm
H30019-ID	19	117	25/30/35/40
H30021-ID	21	129	25/30/35/40
H30023-ID	23	142	25/30/35/40
H30025-ID	25	154	25/30/35/40

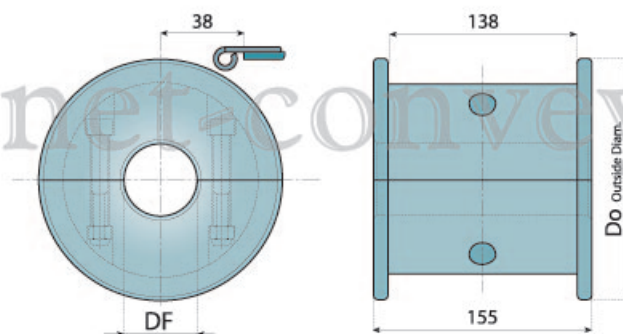

分体式从动轮 (机加工)
SPLIT IDLER WHEELS (MACHINED)

适用于 821-LBP821 链条
FOR 821-LBP821

编号 CODE	齿数 Z	外径 Do mm	孔径 DF mm
H31019-ID-1	19	117	25/30/35/40
H31021-ID-1	21	129	25/30/35/40
H31023-ID-1	23	142	25/30/35/40
H31025-ID-1	25	154	25/30/35/40

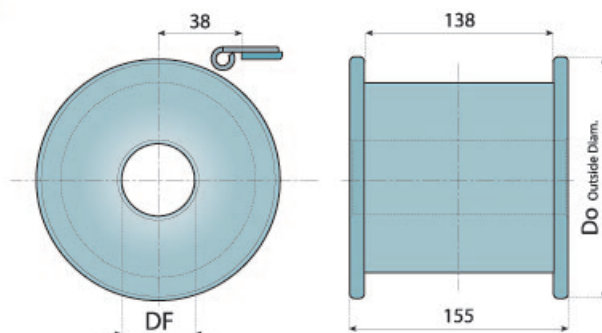

整体式从动轮 (机加工)
SINGLE - PIECE IDLER WHEELS (MACHINED)

编号 CODE	齿数 Z	外径 Do mm	孔径 DF mm
H31019-ID-2	19	117	25/30/35/40
H31021-ID-2	21	129	25/30/35/40
H31023-ID-2	23	142	25/30/35/40
H31025-ID-2	25	154	25/30/35/40



分体式主动轮 (注塑)
SPLIT SPROCKETS (INJECTION)

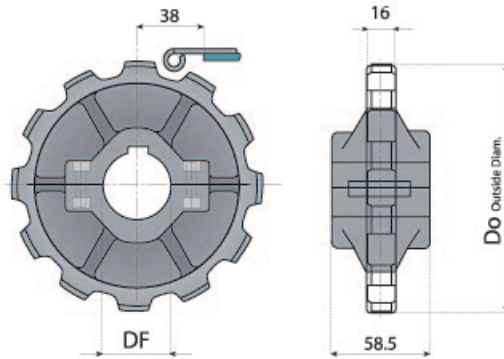

适用于 880-880M-880TAB-878TAB-880BS-RT880 链条
FOR 880-880M-880TAB-878TAB-880BS-RT880

编号 CODE	齿数 Z	外径 Do mm	孔径 DF mm
I32010	10	122	25/30/35/40
I32012	12	147	25/30/35/40



分体式主动轮 (机加工)
SPLIT SPROCKETS (MACHINED)

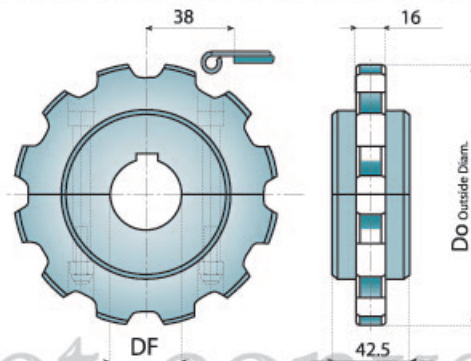

适用于 880-880M-880TAB-878TAB-880BS-RT880 链条
FOR 880-880M-880TAB-878TAB-880BS-RT880

编号 CODE	齿数 Z	外径 Do mm	孔径 DF mm
I33009-1	9	110	25/30/35/40
I33010-1	10	122	25/30/35/40
I33011-1	11	135	25/30/35/40
I33012-1	12	147	25/30/35/40



整体式主动轮 (机加工)
SINGLE-PIECE SPROCKETS (MACHINED)

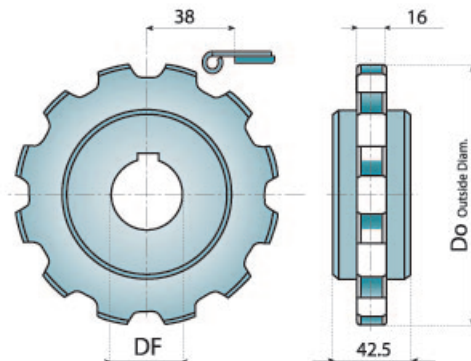

编号 CODE	齿数 Z	外径 Do mm	孔径 DF mm
I33009-2	9	110	25/30/35/40
I33010-2	10	122	25/30/35/40
I33011-2	11	135	25/30/35/40
I33012-2	12	147	25/30/35/40



分体式从动轮 (注塑)
SPLIT IDLER WHEELS (INJECTION)

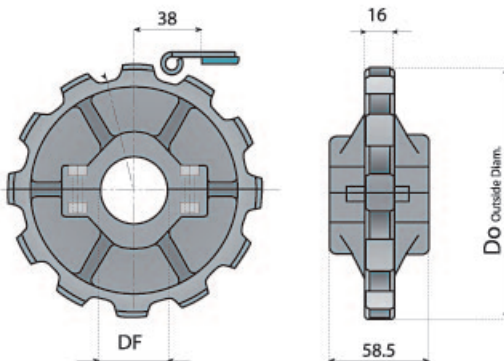

适用于 880-880M-880TAB-878TAB-880BS-RT880 链条
FOR 880-880M-880TAB-878TAB-880BS-RT880

编号 CODE	齿数 Z	外径 Do mm	孔径 DF mm
I34010-ID	10	122	25/30/35/40
I34012-ID	12	147	25/30/35/40

主动链轮和从动轮

Sprockets & Idler Wheels

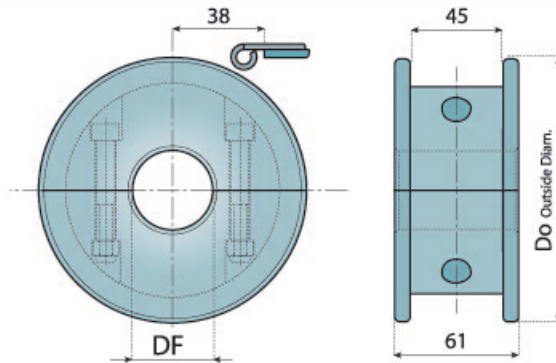

分体式从动轮 (机加工)
SPLIT IDLER WHEELS (MACHINED)

适用于 880-880M 链条
FOR 880-880M

编号 CODE	齿数 Z	外径 Do mm	孔径 DF mm
I35009-ID-1	9	117	25/30/35/40
I35010-ID-1	10	129	25/30/35/40
I35011-ID-1	11	142	25/30/35/40
I35012-ID-1	12	154	25/30/35/40

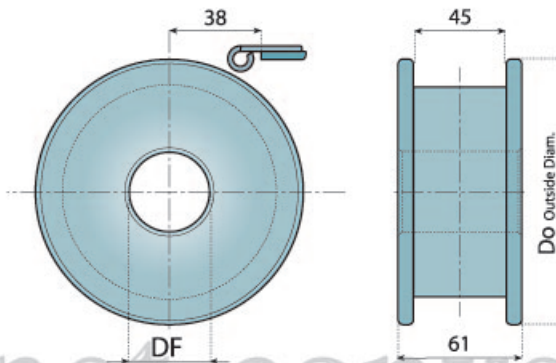

整体式从动轮 (机加工)
SINGLE-PIECE IDLER WHEELS (MACHINED)

编号 CODE	齿数 Z	外径 Do mm	孔径 DF mm
I35009-ID-2	9	117	25/30/35/40
I35010-ID-2	10	129	25/30/35/40
I35011-ID-2	11	142	25/30/35/40
I35012-ID-2	12	154	25/30/35/40

www.net-conveyor.com

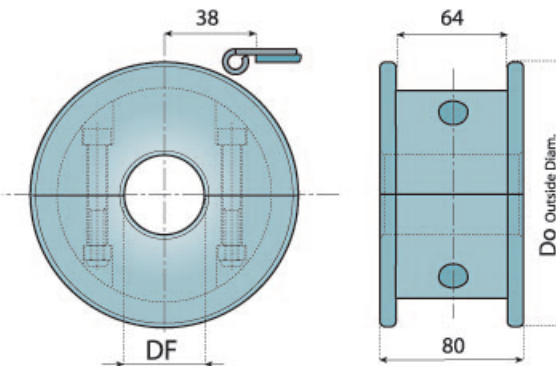

适用于 880TAB-878TAB-880BS-RT880 链条
FOR 880TAB-878TAB-880BS-RT880

编号 CODE	齿数 Z	外径 Do mm	孔径 DF mm
J36009-ID	9	117	25/30/35/40
J36010-ID	10	129	25/30/35/40
J36011-ID	11	142	25/30/35/40
J36012-ID	12	154	25/30/35/40

从动轮 (机加工)
IDLER WHEELS (MACHINED)

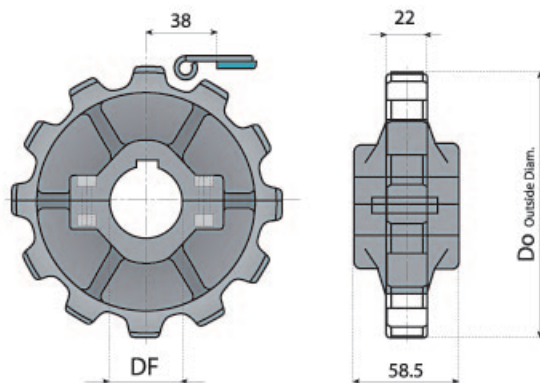

适用于 882BEVEL-882M-882TAB-LBP882TAB 链条
FOR 882BEVEL-882M-882TAB-LBP882TAB

编号 CODE	齿数 Z	外径 Do mm	孔径 DF mm
K37010	10	125	25/30/35/40
K37012	12	149	25/30/35/40

分体式从动轮 (注塑)
SPLIT SPROCKETS (INJECTION)

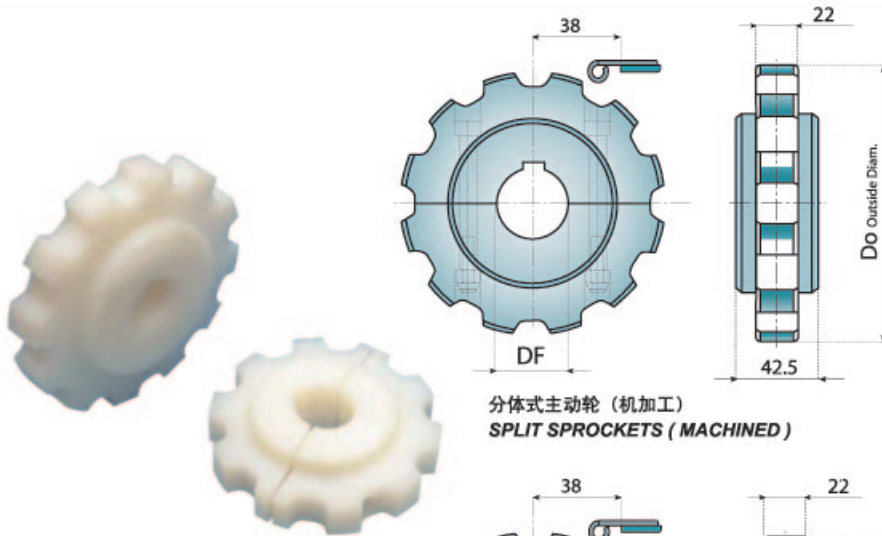

分体式主动轮 (机加工)
SPLIT SPROCKETS (MACHINED)

适用于 882BEVEL-882M-882TAB-LBP882TAB 链条
FOR 882BEVEL-882M-882TAB-LBP882TAB

编号 CODE	齿数 Z	外径 Do mm	孔径 DF mm
K38009-1	9	110	25/30/35/40
K38010-1	10	125	25/30/35/40
K38011-1	11	137	25/30/35/40
K38012-1	12	149	25/30/35/40

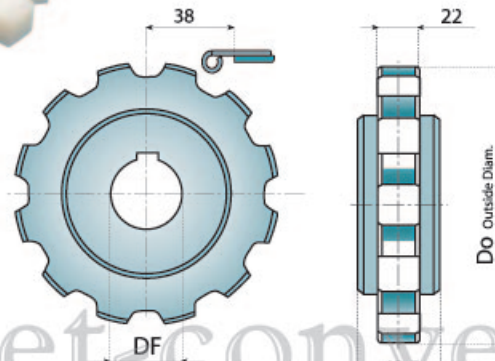

整体式主动轮 (机加工)
SINGLE-PIECE SPROCKETS (MACHINED)

编号 CODE	齿数 Z	外径 Do mm	孔径 DF mm
K38009-2	9	110	25/30/35/40
K38010-2	10	125	25/30/35/40
K38011-2	11	137	25/30/35/40
K38012-2	12	149	25/30/35/40

www.net-conveyor.com



从动轮 (机加工)
IDLER WHEELS (MACHINED)

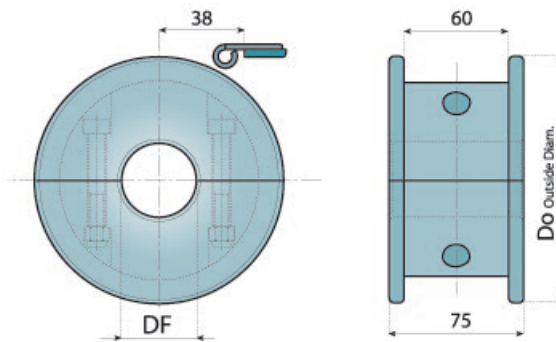

适用于 882M 链条
FOR 882M

编号 CODE	齿数 Z	外径 Do mm	孔径 DF mm
K39009-ID	9	117	25/30/35/40
K39010-ID	10	129	25/30/35/40
K39011-ID	11	142	25/30/35/40
K39012-ID	12	154	25/30/35/40



从动轮 (机加工)
IDLER WHEELS (MACHINED)

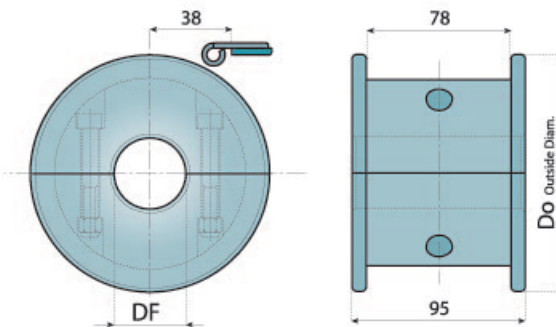

适用于 882TAB 链条
FOR 882TAB

编号 CODE	齿数 Z	外径 Do mm	孔径 DF mm
K40009-ID	9	117	25/30/35/40
K40010-ID	10	129	25/30/35/40
K40011-ID	11	142	25/30/35/40
K40012-ID	12	154	25/30/35/40